



Installation Manual for D1520 Series EN Compliant Grade 2 Type A Power Supplies

D1520 Series	
D1520	Grade 2, ½ A
D1521	Grade 2, 1A
D1522	Grade 2, 2A

INSTALLATION

Mount the metal enclosure onto the wall.

Connect the Live, Earth and Neutral terminals to an un-switched fused spur.

Connect the tamper and fault outputs to the control panel as appropriate (see control panel manual for details).

Connect the 12v power output to the system.

Ensure that the tamper switch is connected to the PCB.

Fit the batteries.

Switch on the AC supply and confirm that the "EPS" and "APS" LEDs are on.

**This product is suitable for use in systems designed to comply with
PD6662:2004 at Grade 2 and Environmental Class 2.**

Dycon Ltd

Tel: +44 (0)1443 471 060 - Fax: +44 (0)1443 479 374
Cwm Cynon Business Park – Mountain Ash – CF45 4ER - UK
www.dyconsecurity.com - sales@dyconsecurity.com

External power supply (AC supply)

The power supply has a three-way terminal block for Live, Earth and Neutral connections, and is protected by a 20mm anti-surge fuse. Mains earth is isolated from the 0V output although, when supplied boxed, mains earth is connected to the metal enclosure.

Tamper output

This voltage free output is connected to the tamper connector. These terminals will be shorted when the tamper switch is fitted and closed.

Fault outputs

Two voltage free fault outputs and LEDs are provided to monitor for External Power Supply (EPS) fault and for Auxiliary Power Supply (APS) fault.

EPS FAULT	APS FAULT
Green LED goes out and relay contacts open if:	Green LED goes out and relay contacts open if:
AC power fault	Battery voltage lower than 10.8v
Unit powered down	Unit powered down
Thermal shutdown	
Both outputs open and all LEDs out indicates a total power-down	

12V power output

Terminal blocks are provided to connect to the system. The maximum current available from the "Power output" terminals depends on the type of power supply and the batteries used, shown in the table on 4. The "12V OK" LED indicates that 12V is available from these terminal blocks.

Auxiliary power supply (batteries)

Two battery connectors are provided marked BATT1 and BATT2. The D1522 has a third battery connector marked BATT3. These power supplies are compatible with 7AH or 8AH Sealed Lead Acid or Gel batteries.

If two batteries are to be used, they must be fitted to BATT1 and BATT2.

If three batteries are to be used on the D1522, they are fitted to all three connectors.

Battery protection

The batteries and electronic circuitry are protected against reverse polarity connection by a self resetting electronic fuse. The batteries are also protected against deep discharge, which will be invoked when the battery terminal voltage has dropped to 10.5v.

Specifications

Power supply	Type A, Security Grade 2, Environmental Class 2
AC input voltage	230v +10% -15%, 50Hz ± 15%
AC input fuse	20mm anti-surge fuse rated at:
- D1520 and D1521	- 230V, 1A
- D1522	- 230V, 3A
Output voltage	13.7v nominal
Output ripple	Less than 50mV (less than 0.4% @ 13.7v)
Battery recharge time	Less than 72 hours
Operating temperature range	-10°C to +40°C

Maintenance

This unit is to be used by service personnel only; there are no user serviceable parts. No maintenance is required other than routine periodic testing and replacement of the standby batteries. For further information on routine battery replacement, please contact your battery supplier or manufacturer.

PSU rating

Power supplies conforming to the new European standards are specified differently from older designs. The following information will give a rough idea of how to compare the current availability figures for new power supplies. The “New Rating” current can be drawn from the PSU even when the standby batteries are flat.

Example: an EN compliant power supply rated at 1A is able to provide 1A to the system even with flat batteries connected and the mains supply at its minimum rating. To achieve this, a 1A power supply could have an *overall* rating of up to 2.5A.

Current available

To meet the standby durations for PD6662, it is important that the current taken from the power supply does not exceed the figures in the table below. To meet the requirements of EN50131-1, the figures below must be divided by 2.2 (e.g. 1.5A becomes 0.68A).

Current available for systems

	D1520	D1521	D1522		D1520	D1521	D1522
1 x 7 AH	0.5A	0.5A	0.5A	1 x 8 AH	0.5A	0.6A	0.6A
2 x 7 AH	0.5A	1.0A	1.0A	2 x 8 AH	0.5A	1.0A	1.2A
3 x 7 AH	N/A	N/A	1.5A	3 x 8 AH	N/A	N/A	1.8A
1 x 17 AH	N/A	N/A	1.3A	1 x 18 AH	N/A	N/A	1.4A
2 x 17 AH	N/A	N/A	2.0A	2 x 18 AH	N/A	N/A	2.0A

Product part numbers

D1520-A	Grade 2, 1/2A PSU in “A” size housing to accept a single 7 AH / 8AH battery
D1520-B	Grade 2, 1/2A PSU in “B” size housing to accept a single 7 / 8 AH battery and ancillary equipment
D1521-B	Grade 2, 1A PSU in “B” size housing to accept 7 / 8 AH batteries
D1522-B	Grade 2, 2A PSU in “B” size housing to accept 7 / 8 AH batteries
D1522-C	Grade 2, 2A PSU in “C” size housing to accept 7 / 8 / 17 / 18 AH batteries

Sizes and weights

	PCB	“A” size housing	“B” size housing	“C” size housing
Size (h x w x d mm)	130 x 100 x 38	235 x 170 x 85	260 x 320 x 87	430 x 345 x 90
Weight (kg)	0.19	2.0	3.2	4.5

LAYOUT – D1520 and D1521

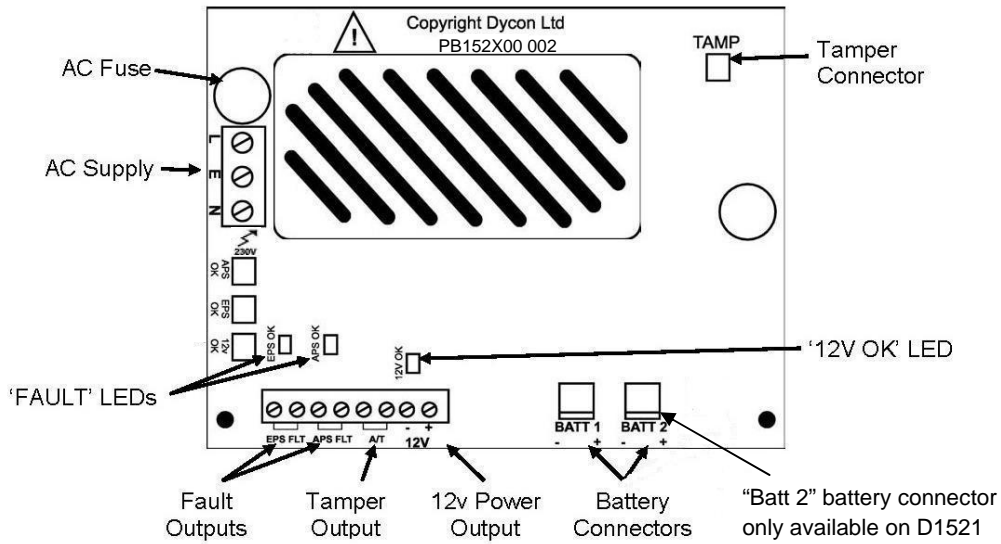

LAYOUT – D1522

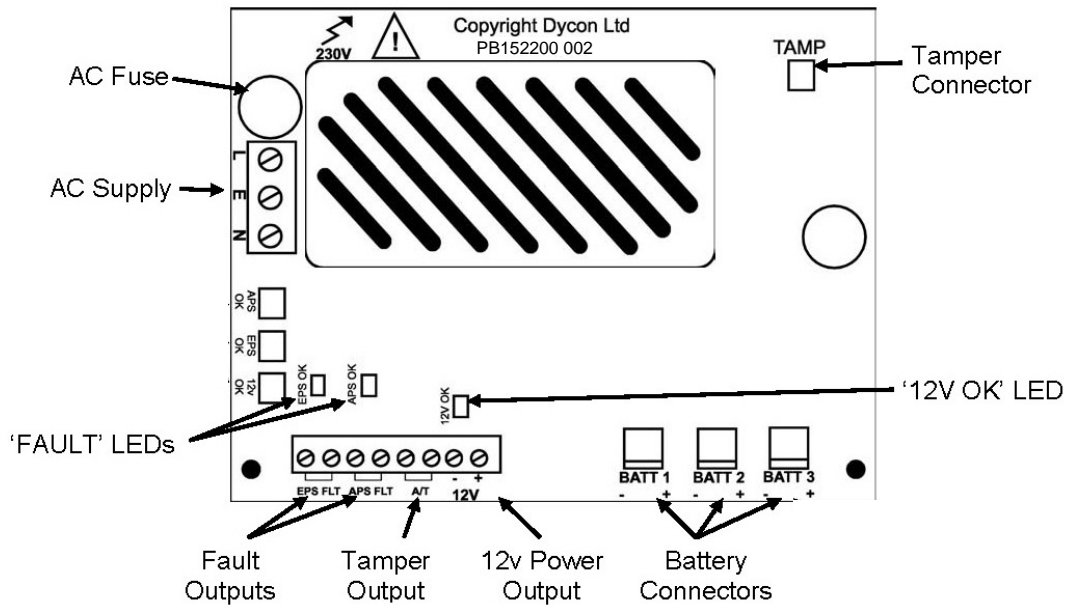

In case of problems, telephone Dycon Technical Support on +44 (0)1443 471064,
or email technical@dyconsecurity.com.